



# Digitalna vezja UL, FRI



Vaja 2 PDNO in PKNO

# Zapis popolnih oblik preklopnih funkcij

**Normalna oblika** – dva nivoja operatorjev; na posameznem nivoju le en operator

**Popolna oblika** – v vseh izrazih prvega nivoja so vse spremenljivke

## Popolna disjunktivna normalna oblika (PDNO)

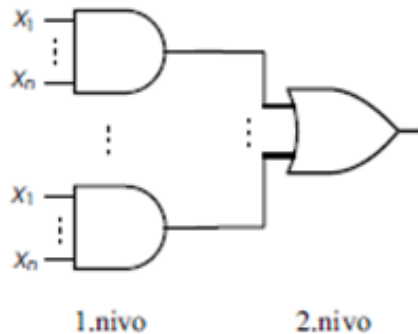

$$f(x_1, x_2, \dots, x_n) = \bigvee_{i=0}^{2^n-1} m_i f(\vec{w}_i)$$

$f(\vec{w}_i)$  ... vrednost funkcije pri  $i$ -tem vhodnem vektorju (vrstici)

$m_i$  ... minterm  $i$ ;  $m_i = x_1^{w_{1,i}} \cdot x_2^{w_{2,i}} \cdot \dots \cdot x_n^{w_{n,i}}$ ;  $i = 0, 1, 2, \dots, 2^n - 1$

$$x^w = \begin{cases} x, & w = 1 \\ \bar{x}, & w = 0 \end{cases}$$

$w_{j,i}$ ... $j$ -ti bit binarnega zapisa števila  $i$

## Popolna konjunktivna normalna oblika (PKNO)

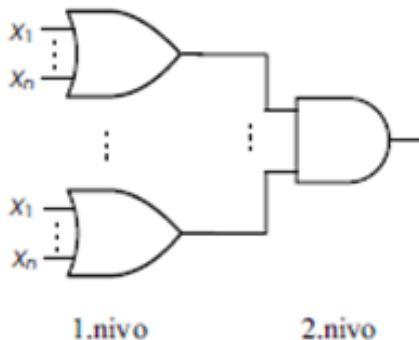

$$f(x_1, x_2, \dots, x_n) = \big\&_{i=0}^{2^n-1} (M_i \vee f(\vec{w}_i))$$

$f(\vec{w}_i)$  ... vrednost funkcije pri  $i$ -tem vhodnem vektorju (vrstici)

$M_i$  ... maksterm  $i$ ;  $M_i = \bar{x}_1^{w_{1,i}} \vee \bar{x}_2^{w_{2,i}} \vee \dots \vee \bar{x}_n^{w_{n,i}}$ ;  $i = 0, 1, 2, \dots, 2^n - 1$

# Primer: Preklopna funkcija $f(x_1, x_2, x_3)$

**Minterm** – konjunkcija vhodnih spremenljivk  $x_1, x_2, x_3$ . Spremenljivka  $x_i$  je negirana, če je vhodna vrednost enaka 0, in je nenegirana, če je vhodna vrednost enaka 1.

**Maksterm** - disjunkcija vhodnih spremenljivk  $x_1, x_2, x_3$ . Spremenljivka  $x_i$  je negirana, če je vhodna vrednost enaka 1 in je nenegirana, če je vhodna vrednost enaka 0.

$x_1$	$x_2$	$x_3$	$f(x_1, x_2, x_3)$	minterm	maksterm
0	0	0	$f(\overline{w_0})$	$m_0 = \overline{x_1} \cdot \overline{x_2} \cdot \overline{x_3}$	$M_0 = x_1 \vee x_2 \vee x_3$
0	0	1	$f(\overline{w_1})$	$m_1 = \overline{x_1} \cdot \overline{x_2} \cdot x_3$	$M_1 = x_1 \vee x_2 \vee \overline{x_3}$
0	1	0	$f(\overline{w_2})$	$m_2 = \overline{x_1} \cdot x_2 \cdot \overline{x_3}$	$M_2 = x_1 \vee \overline{x_2} \vee x_3$
0	1	1	$f(\overline{w_3})$	$m_3 = \overline{x_1} \cdot x_2 \cdot x_3$	$M_3 = x_1 \vee \overline{x_2} \vee \overline{x_3}$
1	0	0	$f(\overline{w_4})$	$m_4 = x_1 \cdot \overline{x_2} \cdot \overline{x_3}$	$M_4 = \overline{x_1} \vee x_2 \vee x_3$
1	0	1	$f(\overline{w_5})$	$m_5 = x_1 \cdot \overline{x_2} \cdot x_3$	$M_5 = \overline{x_1} \vee x_2 \vee \overline{x_3}$
1	1	0	$f(\overline{w_6})$	$m_6 = x_1 \cdot x_2 \cdot \overline{x_3}$	$M_6 = \overline{x_1} \vee \overline{x_2} \vee x_3$
1	1	1	$f(\overline{w_7})$	$m_7 = x_1 \cdot x_2 \cdot x_3$	$M_7 = \overline{x_1} \vee \overline{x_2} \vee \overline{x_3}$

# PDNO

Zapišite PDNO za preklopno funkcijo  $f(x_1, x_2, x_3) = x_1 \cdot \bar{x}_2 \vee x_2 \cdot x_3$ .

$x_1$	$x_2$	$x_3$	$f(x_1, x_2, x_3)$	minterm
0	0	0	0	$m_0 = \bar{x}_1 \cdot \bar{x}_2 \cdot \bar{x}_3$
0	0	1	0	$m_1 = \bar{x}_1 \cdot \bar{x}_2 \cdot x_3$
0	1	0	0	$m_2 = \bar{x}_1 \cdot x_2 \cdot \bar{x}_3$
0	1	1	1	$m_3 = \bar{x}_1 \cdot x_2 \cdot x_3$
1	0	0	1	$m_4 = x_1 \cdot \bar{x}_2 \cdot \bar{x}_3$
1	0	1	1	$m_5 = x_1 \cdot \bar{x}_2 \cdot x_3$
1	1	0	0	$m_6 = x_1 \cdot x_2 \cdot \bar{x}_3$
1	1	1	1	$m_7 = x_1 \cdot x_2 \cdot x_3$

$$\begin{aligned} f(x_1, x_2, x_3) &= m_0 \cdot 0 \vee m_1 \cdot 0 \vee m_2 \cdot 0 \vee m_3 \cdot 1 \vee m_4 \cdot 1 \vee m_5 \cdot 1 \vee m_6 \cdot 0 \vee m_7 \cdot 1 \\ &= m_3 \vee m_4 \vee m_5 \vee m_7 = \\ &= \vee^3 (3, 4, 5, 7) = \\ &= \bar{x}_1 \cdot x_2 \cdot x_3 \vee x_1 \cdot \bar{x}_2 \cdot \bar{x}_3 \vee x_1 \cdot \bar{x}_2 \cdot x_3 \vee x_1 \cdot x_2 \cdot x_3 \end{aligned}$$

# PKNO

Zapište PKNO za preklapno funkciju  $f(x_1, x_2, x_3) = x_1 \cdot \bar{x}_2 \vee x_2 \cdot x_3$ .

$x_1$	$x_2$	$x_3$	$f(x_1, x_2, x_3)$	<b>maksterm</b>
0	0	0	0	$M_0 = x_1 \vee x_2 \vee x_3$
0	0	1	0	$M_1 = x_1 \vee x_2 \vee \bar{x}_3$
0	1	0	0	$M_2 = x_1 \vee \bar{x}_2 \vee x_3$
0	1	1	1	$M_3 = x_1 \vee \bar{x}_2 \vee \bar{x}_3$
1	0	0	1	$M_4 = \bar{x}_1 \vee x_2 \vee x_3$
1	0	1	1	$M_5 = \bar{x}_1 \vee x_2 \vee \bar{x}_3$
1	1	0	0	$M_6 = \bar{x}_1 \vee \bar{x}_2 \vee x_3$
1	1	1	1	$M_7 = \bar{x}_1 \vee \bar{x}_2 \vee \bar{x}_3$

$$\begin{aligned} f(x_1, x_2, x_3) &= (M_0 \vee 0) \cdot (M_1 \vee 0) \cdot (M_2 \vee 0) \cdot (M_3 \vee 1) \cdot (M_4 \vee 1) \cdot (M_5 \vee 1) \cdot (M_6 \vee 0) \cdot (M_7 \vee 1) \\ &= M_0 \cdot M_1 \cdot M_2 \cdot M_6 = \\ &= \&^3(0, 1, 2, 6) = \\ &= (x_1 \vee x_2 \vee x_3) \cdot (x_1 \vee x_2 \vee \bar{x}_3) \cdot (x_1 \vee \bar{x}_2 \vee x_3) \cdot (\bar{x}_1 \vee \bar{x}_2 \vee x_3) \end{aligned}$$

# Naloga

Preklopni funkciji  $f(x_1, x_2, x_3) = x_1 \cdot \overline{x_2} \vee \overline{x_3}$  določite pravilnostno tabelo ter zapišite PDNO in PKNO v skrajšani in eksplicitni obliki. Dobljen PKNO nato narišite v Logisimu.

$x_1$	$x_2$	$x_3$	$f(x_1, x_2, x_3)$	minterm	maksterm
0	0	0		$m_0 = \overline{x_1} \cdot \overline{x_2} \cdot \overline{x_3}$	$M_0 = x_1 \vee x_2 \vee x_3$
0	0	1		$m_1 = \overline{x_1} \cdot \overline{x_2} \cdot x_3$	$M_1 = x_1 \vee x_2 \vee \overline{x_3}$
0	1	0		$m_2 = \overline{x_1} \cdot x_2 \cdot \overline{x_3}$	$M_2 = x_1 \vee \overline{x_2} \vee x_3$
0	1	1		$m_3 = \overline{x_1} \cdot x_2 \cdot x_3$	$M_3 = x_1 \vee \overline{x_2} \vee \overline{x_3}$
1	0	0		$m_4 = x_1 \cdot \overline{x_2} \cdot \overline{x_3}$	$M_4 = \overline{x_1} \vee x_2 \vee x_3$
1	0	1		$m_5 = x_1 \cdot \overline{x_2} \cdot x_3$	$M_5 = \overline{x_1} \vee x_2 \vee \overline{x_3}$
1	1	0		$m_6 = x_1 \cdot x_2 \cdot \overline{x_3}$	$M_6 = \overline{x_1} \vee \overline{x_2} \vee x_3$
1	1	1		$m_7 = x_1 \cdot x_2 \cdot x_3$	$M_7 = \overline{x_1} \vee \overline{x_2} \vee \overline{x_3}$

PDNO:  $f(x_1, x_2, x_3) = ?$

PKNO:  $f(x_1, x_2, x_3) = ?$

# Pretvorba PDNO $\leftrightarrow$ PKNO

---

## Relacije med mintermi in makstermi:

$$\begin{array}{ll} \overline{m_i} = M_i & m_i \vee M_i = 1 \\ \overline{M_i} = m_i & m_i \cdot M_i = 0 \end{array}$$

## Pretvorba PDNO $\leftrightarrow$ PKNO:

1. Funkcijo negiramo (izpišemo komplementarne terme).
2. Manjkajoči indeksi predstavljajo indekse dualnih termov.

$$f(x_1, x_2, x_3) = x_1 \cdot \overline{x_2} \vee x_2 \cdot x_3$$

**PDNO:**  $\vee^3 (3, 4, 5, 7)$

$\leftrightarrow$

**PKNO:**  $\&^3 (0, 1, 2, 6)$

□ Pretvorite podano funkcijo iz ene popolne normalne oblike v drugo:

1.  $\vee^4 (1, 3, 4, 6, 7, 8, 12, 14, 15)$  pretvorite v PKNO.
2.  $\&^4 (0, 7, 8, 10, 11, 12)$  pretvorite v PDNO.